

INSTRUCTION MANUAL FOR PLASMA ARC CUTTING DEVICE



Read this manual carefully before using the machine. Failure to respect the rules described herein shall exempt the manufacturer from any liability.

The machine has been designed, built and protected (per standards: IEC 974.1 - EN 60974.1) for the functions described below. Any other use not explicitly included shall be considered FORBIDDEN.

The machine must be used in sufficiently ventilated rooms, in the absence of dust and moisture; in any case, where there is no risk of fire, explosion, or flooding.

The machine must be started, used and serviced by qualified personnel. Always follow current safety regulations.

The manufacturer shall not be held responsible for any damage caused by incorrect use of the machine.

INTRODUCTION

This device must be used exclusively for cutting on any electrically conductive material (metals and alloys).

PLASMA cutting takes place due to the high temperature generated by a concentrated electric arc, and thus highly dangerous situations may arise; it is therefore essential to pay the utmost attention to the chapter entitled SAFETY PRECAUTIONS.

The symbols next to certain paragraphs indicate points requiring extra attention, practical advice or simple information.

This manual must be kept carefully in a place familiar to everyone involved in using the machine. It must be consulted whenever doubts arise and be kept for the entire life-span of the machine; it will also be used for ordering replacement parts.

1 INSTALLATION

1.1 UNPACKING AND ASSEMBLY

Open the upper portion of the packing. Remove the torch, supplied separate from the machine. Remove the two eyebolts from the accessories box and screw them onto the machine using the two Belleville washers. Use a lift to remove the device from the packing. Mount the two casters on the front and the two wheels on the back. Mount the handle, following the drawing in Fig. 1. This handle shall not be used to lift the machine.

Place the device in an adequately ventilated room, taking care

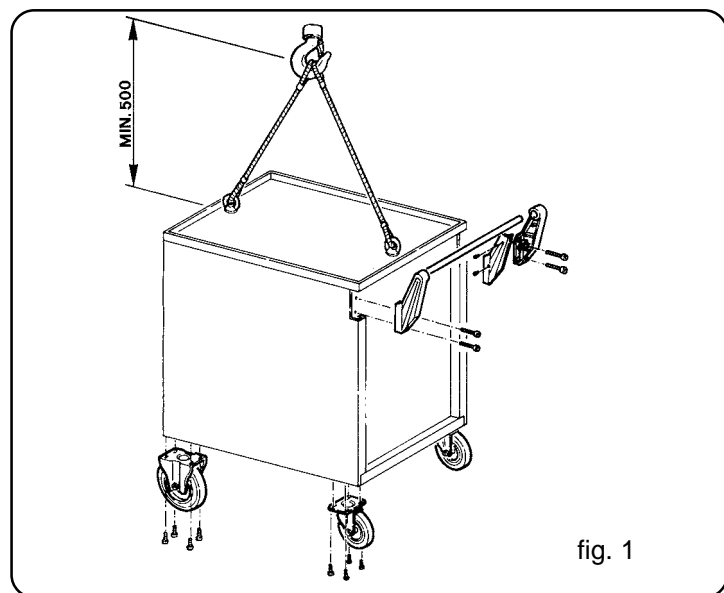

fig. 1

not to block the air circulation through the cooling slots.

1.2 TORCH ASSEMBLY

This system is suitable for use only with CEBORA P70 and P150 torches, both manual and automatic.

After inserting the torch fitting **Q** into the guard **G**, insert the torch into the fixed connector **P**, screwing the ring-nut of the fitting **Q** all the way down to avoid any air leaks, which could damage or interfere with smooth operation of the torch.

Do not dent the terminal pin or bend the pegs in the torch fitting

Q. A dented pin cannot be connected, while a bent peg does not allow the fitting **Q** to be fitted firmly into the fixed connector **P**, preventing the machine from operating. Screw the guard **G** onto the panel.



1.3 DESCRIPTION OF PARTS

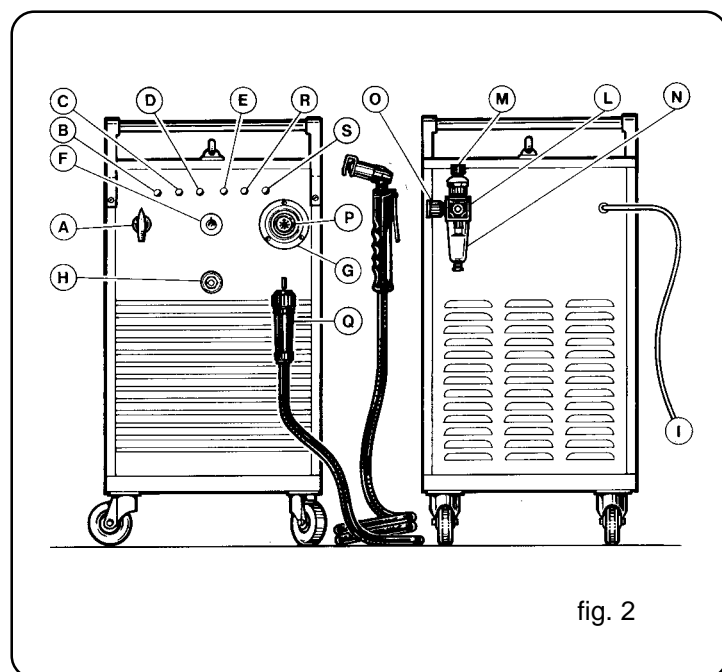





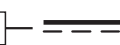





fig. 2



- A) Function switch.
- B) Power indicator lamp.
- C) Thermostat indicator lamp. 
- D) Insufficient air pressure indicator lamp. 
- E) Worn electrode indicator lamp . This lamp lights when the electrode must be replaced
- F) Cutting current setting knob.
- G) Torch fitting guard.
- H) Work cable socket.
- I) Mains cable.
- L) Compressed air fitting (1/4" female gas threading)
- M) Air pressure reducer.
- N) Water trap.
- O) Pressure gauge.
- P) Fixed fitting for torch.
- Q) Torch fitting.
- R) Machine cut-out pilot light (only on PROF 122)
- S) No contact cutting pilot light (only on PROF 122). This lights when it is prohibited to cut with the tip in

contact with the workpiece.

1.4 EXPLANATION OF TECHNICAL SPECIFICATIONS

IEC 974.1 The device is manufactured according to these
EN 60974.1 international standards.

		N°		
3 ~ 		EN 60 974-1		
 TORCH TYPE CEBORA P70-P150	 U₀ V PEAK	X	%	%
		I₂	A	A
		U₂	V	V
				
3 ~		V	A	A
50/60	U₁	V	I₁	A
Hz		V	A	A
PROTEZIONE TERMICA THERMAL PROTECTION PROTECTION THERMIQUE THERMISCH GESCHÜTZT PROTECCION TERMICA		IP 21		VENTILAZIONE FORZATA FORCED VENTILATION VENTILE KUHLART F VENTILACION FORZADA
		CL. H		

- N°** Serial number, to be included in any request regarding the device.
-  Drooping characteristic.
-  Suitable for plasma arc cutting
- TORCH TYPE** Type of torch that may be used with this device.
- U₀** Secondary open-circuit voltage (peak value).
- X** Duty cycle.
This expresses the percentage of 10 minutes during which the device can run at a certain current without overheating.
- I₂** Cutting current.
- U₂** Secondary voltage with cutting current I₂
- U₁** Rated power voltage.
- 3~ 50/60Hz** Three-phase 50- or 60-Hz power supply
- I₁** Absorbed current at the corresponding cutting current I₂
- IP 21** Housing protection rating.
Grade 1 as the second digit means that the machine is not suitable for use outdoors in the rain.
-  Suitable for working in slightly hazardous areas.

NOTE: The device has also been designed to work in areas with a pollution rating of 3 (see IEC 664).

1.5 START-UP

The machine must be installed by qualified personnel. All connections must be in compliance with current standards, and carried out in full respect of safety laws.(CENELEC HD 427).

Connect the air supply to the fitting **L**, making sure that the plant is a position to supply at least 250 l/min at a pressure of 5 bar (0.5 MPa).

If the air supply comes from a compressed air cylinder, it must be equipped with a pressure regulator; **never connect a com-**

pressed air cylinder directly to the machine reducer. The pressure could exceed the capacity of the reducer, causing it to explode.

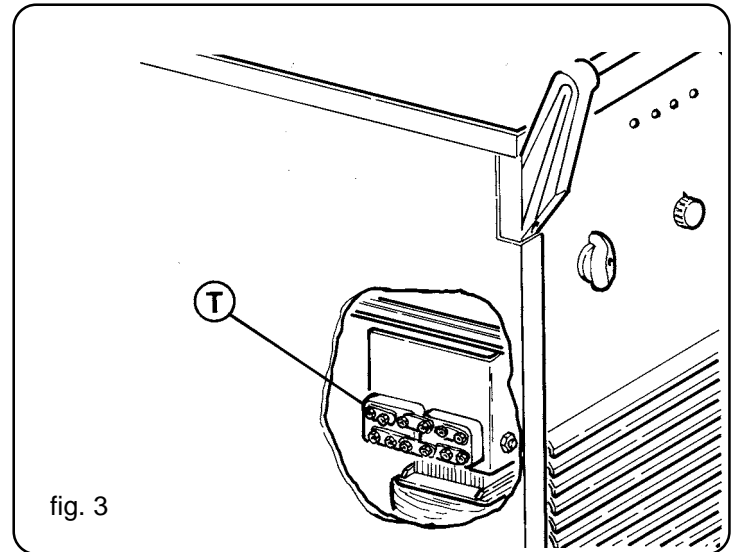

1.5.1 Connection to power mains

Make sure that the supply voltage corresponds to the values shown on the power cord tag. If not, use the voltage change terminal board located inside the unit (fig. 3).

The machines are equipped with a function switch; therefore:
a) If the system is permanently connected to the mains without a plug, a main switch must be inserted with a sufficient capacity, in accordance with the tag values;

b) If the system is plugged into the mains, use a plug having the capacity indicated on the tag. In this case, the plug must be used to fully disconnect the machine from the mains, after first setting the switch **A** (fig. 2) to "0" (off).

The yellow-green wire must be connected to the grounding terminal.

The absorbed current I₁ can be deduced by reading the technical specifications listed on the machine, in relation to the power voltage U₁ available.

Any extensions must have a size suitable for the absorbed current I₁.

1.6 SAFETY DEVICES

This unit is fitted with the following safety devices:

Thermal: 

To avoid overloads, a thermal safety device is located on the power transformer coils. When tripped, it lights the indicator lamp **C** (see Fig. 2).

Pneumatic: 

To prevent the machine from running with insufficient air pressure, a pneumatic safety device is located on the torch feed. When tripped, it lights the indicator lamp **D** (see Fig. 2).

Electrical:

- 1) One device is located on the torch assembly to prevent hazardous voltages from being present on the torch when the tip, diffusor, electrode or shield cup are replaced;
- 2) Another device blocks the machine when the electrode is worn

out to the point of needing replacement. When this occurs, it lights the indicator lamp **E**  (see fig. 2).

3) a further device cuts the machine off in case of malfunction of a power component. This function is evidenced by the pilot lamp **R** on .

To ensure the efficiency of these safety devices:

- **Do not remove or short-circuit the safety devices.**
- **Use only original CEBORA replacement parts.**
- **Always replace any damaged parts of the machine or torch with original CEBORA materials.**
- **Use only CEBORA torches, type P70 and P150.**
- **Do not use the machine uncovered. This is dangerous for the operator and anyone else in the working area, and prevents the machine from cooling properly.**

2 OPERATION

Before using this machine, carefully read the CENELEC standards HD 407 and HD 433 also check insulation of cables.

Turn the device on using the knob **A**. The indicator lamp **B** will light.

The motor-driven fan on the machine is thermostat-controlled, and thus starts only when the generator needs to be cooled.

In machines fitted with an emergency button, set the switch knob to ON; when the indicator lamp lights, the machine status is "ready". Moving the knob to START sets off the starting procedure, which ends when the fan inside the machine starts. The START position of the switch is not latched, thus when the knob is released it returns to the ON position.

If the emergency button is pressed during operation, the machine stops immediately and returns to the "ready" status.

After starting the machine, press the torch button briefly to open the flow of compressed air.

For automatic torches, the torch button is the button or switch on the pantograph connected to the wire, supplied attached to the torch.

Make sure that, at this point, the pressure gauge **O** shows a pressure reading of 5 bars (0.5 MPa); if not, adjust the pressure using the knob **M** on the reducer, then lock the knob by pushing it down.

Connect the work clamp to the workpiece, making sure that there is a good electrical contact between the clamp and workpiece, especially for painted or oxidated metal or pieces with insulated coating.

Do not connect the clamp to the part of the material to be cut off. Welding circuit should not be deliberately placed in direct or indirect contact with protection wire if not in the workpiece.

If earthing is deliberately made on the workpiece by means of protection wire, the connection must be as direct as possible, with the wire having a section at least equal to the welding return current wire and connected to the piece being worked on, in the same place as the return wire, using the return wire terminal or a second earth terminal closeby.

All possible precautions must be taken in order to avoid stray currents.

Use the knob **F** to select the cutting current based on the thickness to be cut, following these guidelines:

Aluminium:	3 ÷ 4 mm	40 ÷ 50A
	8 ÷ 10 mm	80 ÷ 90A
	15 ÷ 18 mm	110 ÷ 120A
	22 ÷ 25 mm	150A

Stainless steel	up to 5 mm	40 ÷ 50A
Mild steel	up to 20 mm	80 ÷ 90A
	up to 30 mm	110 ÷ 120A
	up to 40 mm	150A

The machines cutting current is fully adjustable, allowing the operator to select the correct value according to the work requirement.

Current values higher than those indicated do not interfere with correct operation of the machine or torch, and at times can improve the cutting quality because they reduce the production of waste along the edges of the workpiece.

The hole diameter of the torch tip depends on the cutting current, and must be as follows (also shown on the front panel of the machine):

With	20/50A	tip ø 1.1 mm standard or long
	40/90A	tip ø 1.3 mm
	80/130A	tip ø 1.6 mm
	120/150A	tip ø 1.8 mm

With cutting currents from 20 to 50 A and a standard or long tip diam. 1.1 mm, it is possible to work on contact, thus with the tip resting directly on the material to be cut.

In art. 946 PROF 122, the red pilot light **S** on the front panel indicates that contact cutting is forbidden. This occurs when the cutting voltage is set to greater than 50 A.

In other conditions, it is essential to use a spacer (dual-tip **B** or spring type **A**, Fig. 8) to prevent the tip from coming into direct contact with the workpiece. Keep the torch at a distance of approximately 4 mm for use in automatic mode.

Press the torch button to light the pilot arc. If cutting does not begin after 2 or 3 seconds, the pilot arc will go off, and thus the button must be pressed again to light it.

When possible, the torch must be pulled towards the operator. It is easier to pull than to push. Keep the torch upright while cutting.

When you have finished cutting and released the button, the air continues to come out of the torch for approximately 1 minute and 30 seconds, to allow the torch to cool. It is best to avoid turning the machine off before this time has passed.

If you need to make holes or begin cutting from the center of the workpiece, the torch must be held at an angle and straightened slowly, to prevent melted metal from being sprayed onto the tip (see fig. 4). This must be done when *si foran* pieces more than 3 mm thick.

In automatic mode (see fig. 5), keep the tip 7/8 mm from the workpiece; after making the hole, if possible, move it to a distance of approximately 4 mm. Do not drill thicknesses greater than 10/12 mm. For thicker pieces, the workpiece must be perforated before cutting.

If you need to cut on the corners or in notches (Fig. 6), we recommend that you use extended electrodes and tips. If circular cutting is required, we recommend that you use the special

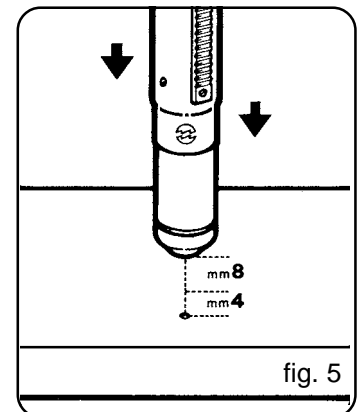
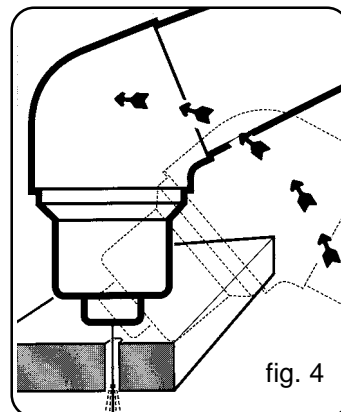

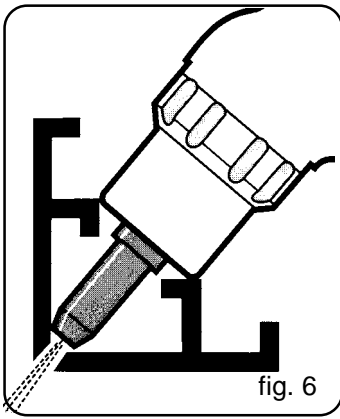

compass supplied upon request. Remember that the compass may make it necessary to use the starting technique described above.

NOTE: Avoid keeping the pilot arc lit needlessly when not using the device, to prevent unnecessary wear on the electrode, diffusor and tip.

When you have finished working, turn off the machine.

2.1 GOUGING

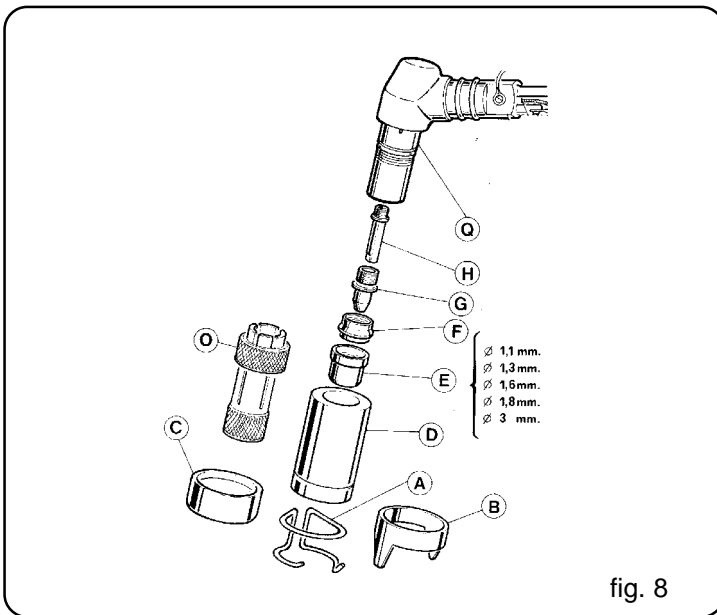
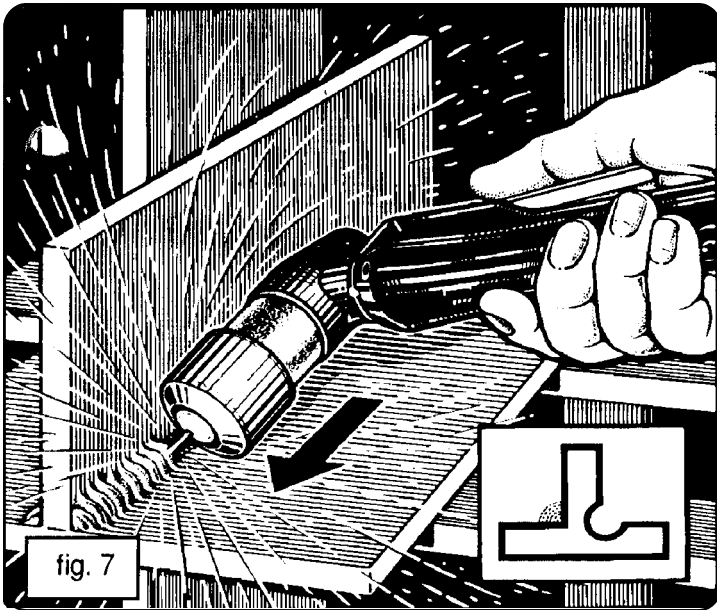

This machine may be used for gouging, making it possible to remove defective welds, separate welded pieces, prepare edges, etc.

To do so, you must use the tip **E** (fig. 8), diam. 3 mm, and mount the spacer **C** on the shield cup bushing **D**. The spacer **C** serves to prevent melted metal from burning the insulation on the shield

cup bushing **D** during gouging.

The current to be used ranges from 70 to 120/150 A, based on the thickness and amount of material to be removed.

This must be done holding the torch at an angle (fig. 7) and moving towards the melted material so that the compressed air leaving the torch pushes it away. The angle of the torch with respect to the workpiece depends on the penetration desired. Since melted waste tends to stick to the spacer and tip during this procedure, it is best to clean them frequently to prevent certain phenomena (double arc) that can destroy the tip in just a few seconds.

Given the high amount of radiation (infrared and ultraviolet) emitted during this procedure, we recommend that the operator be carefully protected, as well as anyone else near the work area.

When you have finished working, turn off the machine

2.2 USING THE TORCH P70 (UPON REQUEST)

The machine can also operate with the torch P70. When this torch is mounted, the machine automatically sets itself to a cutting current of max. 70 A, and settings are available starting at 20 A.

The workpiece can be cut in contact, using either a standard tip and electrode or a long tip and electrode, but only up to 50 A. The red pilot light **S** will indicate when it is necessary to use the spacer.

NOTE: When using the torch P70, the electrical safety device to block the unit when the electrode is worn could fail to work.

Always turn the machine off after use.

3 CUTTING PROBLEMS

3.1 INSUFFICIENT PENETRATION

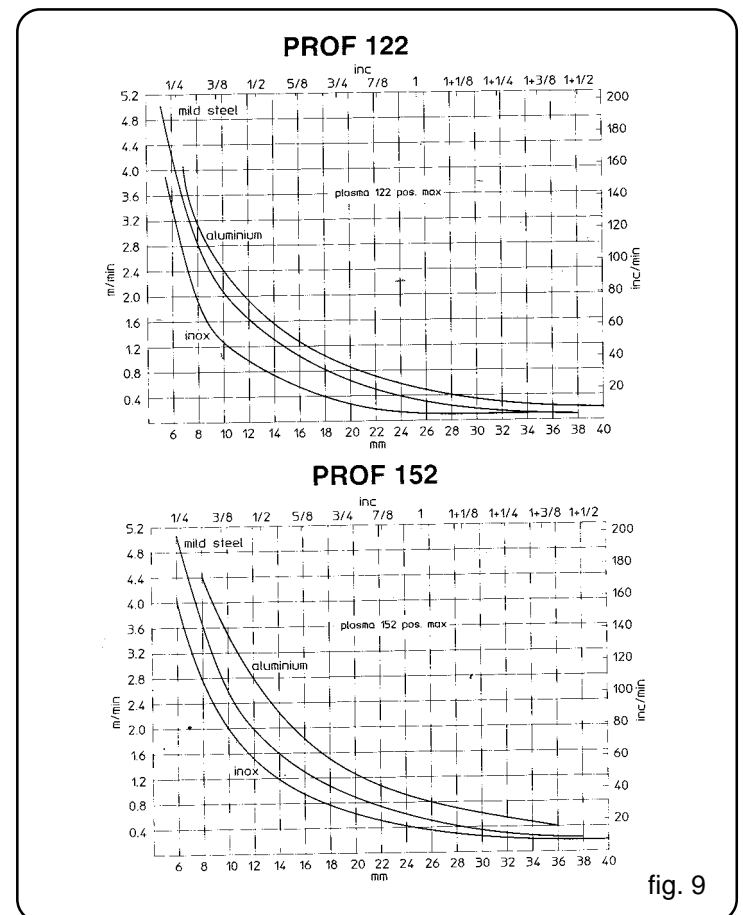

The following may cause this problem:

- Speed too high:
- Always make sure that the arc cuts completely through the workpiece, and that it is never slanted at an angle of more than 10°-15° in the moving direction. This will avoid incorrect consumption of the tip and burns on the shield cup.
- Workpiece is too thick (see cutting speed and thickness diagram, fig. 9)
 - Work clamp is not in good electrical contact with the workpiece.
 - Tip and electrode are worn.
 - Tip hole is too large with respect to the current value set on the knob **F**.
 - Cutting current is too low.
- NOTE: When the arc does not penetrate, the melted metal waste may damage the tip hole.

3.2 THE CUTTING ARC GOES OFF

The following may cause this problem:

- tip, electrode or diffusor is worn;
- air pressure is too high;
- power voltage is too low;
- advancement speed is too slow;
- cutting current is too high in relation to the thickness of the workpiece.

3.3 THE CUT IS SLANTED

If the cut is slanted, turn off the machine and replace the tip. Prevent the tip from coming into electrical contact with the workpiece (even through shreds of melted metal). This causes the nozzle hole to be destroyed rapidly, at times instantaneously, and leads to a poor quality cut.

3.4 EXCESSIVE WEAR ON THE CONSUMABLE PARTS

The following may cause this problem:

- air pressure is too low with respect to the recommended value;
- air supply circuit is damaged.

4 HELPFUL HINTS

- If the air in the system contains considerable amounts of moisture and oil, it is best to use a drying filter to avoid excessive oxidation and wear on the consumable parts, damage to the

torch, and reduced cutting speed and quality.

- Impurities present in the air can also make it difficult to light the pilot arc. If this occurs, clean the end of the electrode and the inside of the tip using very fine sandpaper.
- Make sure that the new electrode and tip about to be mounted have been thoroughly cleaned and degreased.
- To avoid damaging the torch, always use original CEBORA replacement parts.

5 TORCH MAINTENANCE (FIG. 10)

Always cut off power to the machine before working on the torch.

5.1 REPLACING THE CONSUMABLE PARTS

The parts subject to wear are the electrode **G**, the diffusor **F**, and the tip **E**.

Any of these parts may be replaced only after unscrewing the shield cup **D**.

The electrode to be replaced has a crater in the middle, approximately 1.5 mm deep.

If this is not replaced when worn, the device blocks itself and the indicator lamp **E** lights (Fig. 2). To reset, you must turn off the device, replace the electrode and turn it back on using the knob **A**.

CAUTION! Do not use sudden force to unscrew the electrode; exert a gradually progressive force until the threading is released.

Lubricate the threading of the new electrode using silicone lubricant (provided with the machine).

The new electrode must be screwed into its housing and fastened in place without over tightening.

The tip should be replaced when the central hole is damaged or much wider than that of a new tip. The diffusor **F** should be replaced when one of its ends tends to char. Often, due to the thermal and mechanical stress to which it is subjected, this part tends to stick to the electrode **G** or the tip **E**. To detach it, we suggest that you use the extractor **O** provided with the device, which allows you to detach the diffusor without damaging it.

Make sure that the electrode **A**, the diffusor **B** and the tip **C** have been mounted correctly, and that the shield cup **D** is screwed on tightly.

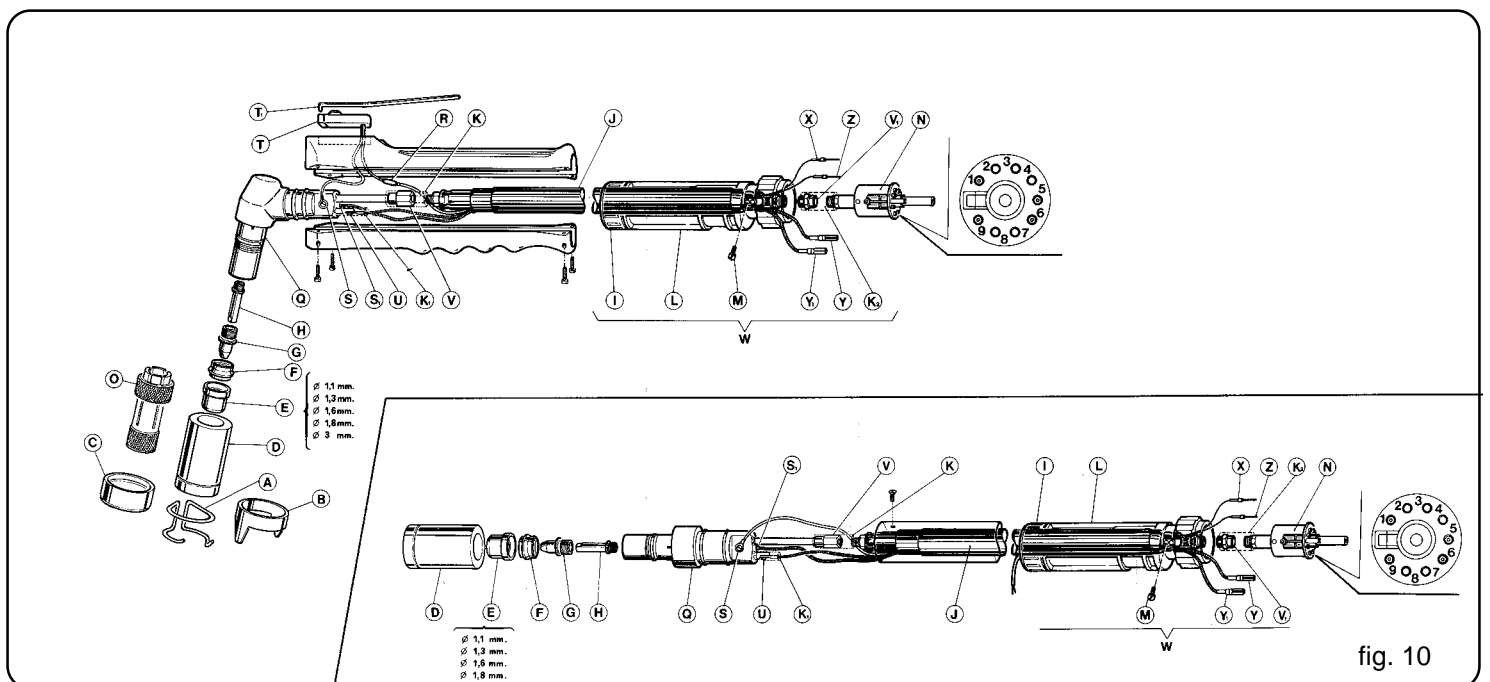

fig. 10

If the unit is used without these parts, it can damage the device and is especially hazardous to the operator's safety.

5.2 REPLACING THE TORCH ASSEMBLY Q

Open the grip by removing the screws. Remove the screws holding the terminals of the safety conductors **S-S1**. Remove the screw holding the conductor for the pilot arc **U** after first cutting the insulating tube **K1**. Remove the fitting **V** after first cutting the insulating tube **K**. Mount the new torch assembly by performing the above steps in reverse order.

The fitting **V** and conductor **U** are insulated by attaching the heat-shrink tubes **K** and **K1** directly to the fittings themselves. Do this by heating the tube with a small heat source (i.e., a cigarette lighter). Before replacing the grip, make sure that all connections have been firmly tightened.

5.3 REPLACING THE TORCH FITTING W

Remove the ring-nut **I** and cut the clamps holding the cable **J**. Unscrew the screw **M** and slide the cover **L** out backwards. Remove the control cable pegs **X** and **Z** and the red pilot arc wire pegs **Y** and **Y1**. Cut the insulating tube **K2** and unscrew the assembly **N** from the fitting **V1**. Mount the new assembly by performing the above steps in reverse order. To lock the thread of assembly **N** onto the fitting **V1**, use sealing adhesive for threads. The pegs **X** and **Z** of the control cable must be connected to contacts 1 and 9 of the assembly **N**. The pegs **Y** and **Y1** of the red cables for the pilot arc must be connected to the contacts 5 and 6 of the assembly **N**. The tube **K2** acts as insulation, and is attached to the fitting **V1** by heating it.

5.4 REPLACING THE CABLE J

To replace the cable, proceed as described in points 5.2 and 5.3. For the manual torch, it is necessary to make the connection **R**. **NOTE:** The connection **R** must be carefully insulated.

5.5 REPLACING THE BUTTON T (manual torch)

Remove the lever **T1**, unscrew the screws and open the grip. Then unscrew the screw **S** holding the cable terminal of the button, cut the connection **R**, remove the button, insert the new button and perform the above steps in reverse order. Insulate the connection **R** carefully.

5.6 REPLACING THE GRIP (manual torch)

The grip can be replaced by following the instructions given in point 5.5.

5.7 REPLACING THE GRIP (torch for use in automatic mode)

The grip can be replaced by following the dismantling instructions given in point 5.2; remove the grip and mount the new one, then follow the previous steps in reverse order to reassemble.

5.8 REPLACING THE DIFFUSOR TUBE H

Unscrew the shield cup **D**, remove the tip **E** and the diffusor **F**; unscrew the electrode **G** and then the tube **H**. Mount the new diffusor tube by screwing it on with the 6-gauge wrench provided, then perform the above steps in reverse order.

6 MAINTENANCE AND CHECKS

Before opening the machine, always disconnect the plug from the mains.

The motor-driven fan on the machine is thermostat-controlled, and thus starts only when the generator needs to be cooled. In case of repairs inside the machine, make sure that the switch **A** is in "O" position and that the mains cable is disconnected from the socket. The fan not turning does not mean that the machine is OFF.

Any maintenance must be performed only by qualified person-

nel, aware of the risks due to the high voltages necessary in order for the device to operate.

Any operations requiring access to the inside of the machine must be carried out only after unplugging the mains cable from the electrical source.

It is important to keep the tip clean of metal waste. Do not use sharp objects to avoid deteriorating the hole of the tip. If you have trouble removing the electrode, proceed as follows: lubricate the threading of the electrode with penetrating lubricating fluid, then unscrew the electrode. If the threading of the electrode holder support on the torch assembly is damaged while removing the electrode, tap it with a male M11 after first removing the diffuser tube **H** (fig. 8).

To prevent metal residue from remaining inside the torch assembly during this operation, we recommend blowing into the torch with compressed air while tapping.

Although the machine is equipped with an automatic condensation drainage device, which is started each time the air supply is cut off, it is a good habit to periodically make sure that there is no trace of condensation in the tray **N** (fig. 2) of the reducer.

Accumulated metal dust must be cleaned from the inside of the machine periodically, using compressed air.

6.1 PRECAUTIONS TO TAKE AFTER A REPAIR

After making repairs, take care to re-order the cables so that there is sure to be insulation between the primary and secondary sides of the machine. Make sure that the wires cannot come into contact with moving parts or parts that heat during operation. Replace all clamps in their original positions on the machine, to prevent a connection between the primary and secondary circuits if a conductor accidentally breaks or disconnects.

Mount also the screws with the toothed washer in the original position.

7 BASIC SAFETY PRECAUTIONS

7.1 ELECTRIC SHOCK

Electric shock can kill. All electric shocks are potentially fatal.

 This plasma cutter requires high voltages for arc spark starting (approx. 250 ÷ 300 V). The following safety rules must be therefore observed when using the unit:

- Do not touch live parts.
- Insulate yourselves from the piece to be cut and from earth by wearing insulating gloves and clothing
- Keep your clothing (gloves, shoes, hats, dresses) and body dry
- Do not work in humid or wet areas
- Avoid touching or holding by hand the piece to be cut
- Always arrange for a proper insulation against electric shock. Should you work close to or in a dangerous area use all possible precautions.
- If you feel even the slightest electric shock sensation, stop cutting at once. Do not use the machine until the problem is identified and solved.
- Always fit an automatic wall switch with adequate power, if possible close to the machine so as to immediately switch the unit off in an emergency event.
- Check often mains cable, torch cable, earth cable and torch. Never use the unit when one of them is damaged. Replace them immediately.
- Disconnect mains cable from mains before replacing cables or before removing unit covers.
- Always switch the unit off or disconnect it before replacing nozzle, swirl ring, electrode or nozzle holder.
- Do not use the unit without protecting covers.
- Always replace any damaged parts of the unit, torch and cables with original material.
- Never remove torch or unit safety devices.

- Make sure that the supply mains line is equipped with an efficient earth plug.
- Make sure that the work table is connected to an efficient earth plug.
- Any maintenance should be only carried out by qualified personnel aware of the risks due to dangerous voltages necessary to make the unit work.

ATTENTION: Never screw nozzle holder D (see picture 10) to torch body Q without fitting consumables electrode G, diffuser F, nozzle E.



La mancanza di tali particolari compromette il funzionamento dell'apparecchio e la sicurezza dell'operatore

7.2 RADIATIONS

Ultraviolet radiations created by the arc may damage your eyes and burn your skin. Then:



- Wear proper clothing and helmets.
- Do not use contact lenses!! The intense heat coming from the arc may stick them on the cornea.
- Use masks with grade DIN 7 or 8 safety lenses, at least.
- Protect people surrounding the cutting area.

7.3 FUMES

Cutting operations give off fumes and harmful metal dusts which may damage health, therefore:



- Do not work in areas without proper ventilation.
- Keep your head out of fumes.
- In closed rooms use suitable exhaust fans, placed under the cutting area, if possible.
- If ventilation is not enough, use breathing sets approved for this procedure.
- Clean the material to be cut of any solvents or halogen degreasers giving rise to toxic gases when cutting: Some chlorine solvents may decompose with radiation emitted by the arc and create phosgene gas.
- Do not cut plated metals or metals containing lead, graphite, cadmium, zinc, chrome, quicksilver or beryllium unless you have a proper breathing set.
- The electric arc creates ozone. After long exposure to high concentrations of ozone you may have headache, nose, throat and eyes irritation as well as serious congestion and chest pains.

IMPORTANT: DO NOT USE OXYGEN FOR VENTILATION.

7.4 FIRE

- Avoid causing fire because of sparks, hot metal or pieces.
- Make sure that suitable fireproof devices are available close to cutting area.
- Remove from cutting area and surrounding area (33 feet at least) all inflammable and combustible material.
- Do not cut containers of combustible or lubricating material, even when empty. These should be carefully cleaned before being cut.
- Let the material cut cool down before touching it or putting it in contact with combustible or inflammable material.
- Do not cut parts with hollow spaces including inflammable material.
- Do not work under conditions of high concentration of combustible vapours, gases or inflammable dust.
- Always check the work area half an hour after cutting so as to make sure that no fire is starting to burn.

7.5 BURNS

- Wear fire-proof clothes all over your body to protect your skin against burns caused by ultraviolet radiations from the arc, from sparks and hot metal.
- Wear no turn-up trousers to prevent sparks and metal to deposit

in them.

- Wait for the torch to be cooled down and then switch the unit off before touching the front side of the torch.
- **Torch is provided with a pilot arc, then as soon as you press the button, the plasma spark starts even if earth cable is not connected. Avoid directing jet towards your own body or towards other people surrounding the cutting area.**
- **To prevent spark to starts by chance, always switch the unit off before putting down your torch.**
- Do not carry combustible material, such as lighters or matches in pocket.

7.6 EXPLOSIONS

- Do not cut above or near containers under pressure.
- Do not cut in environments containing explosive dusts, gases or vapours.



This plasma cutter uses compressed air to work; should you use compressed air bottles follow suitable precautions:

A) CYLINDERS

- Do not directly connect cylinders to reducing unit without a pressure regulator; pressure might exceed the reducing unit capacity making it explode.
- Feeding pressure must not exceed 120 PSI (8bar/0.8 MPa)
- Handle or use pressure cylinders in conformity with the existing rules.
- Do not use leaking or damaged cylinders.
- Do not use cylinders which are not properly secured.
- Do not carry cylinders whose content is not clearly identified.
- Never lubricate cylinder valves with oil or grease.
- Do not put electrically in contact cylinder with plasma arc.
- Do not expose cylinders to excessive heat, sparks, hot metal or flames.
- Do not tamper with cylinder valves.
- Do not try to loosen all tight valves by means of hammers, keys or something else.

B) PRESSURE REGULATORS

- Keep pressure regulators in good conditions. Damaged regulators may give rise to damage or accidents; they should only be repaired by skilled personnel.
- Do not use regulators for gases other than those they are manufactured for.
- Never use a leaking or damaged regulator.
- Never lubricate regulators with oil or grease.

C) AIR HOSES

- Replace air hoses if damaged.
- Keep hoses unwound so as to avoid bending.
- Keep excess hose wound and keep it out of the working area to avoid any damage.

7.7 NOISE

These power sources alone do not produce noise levels exceeding 80 dB. The cutting procedure, however, may produce noise levels in excess of 80 dB in which case the operator must take the necessary safety precautions as prescribed by the national safety regulations.



7.8 PACEMAKER

Magnetic fields created by the high currents in the cutting circuit can affect pacemaker operation. Persons wearing electronic life support equipment (pacemakers) should consult their doctor before going near any arc welding, gouging, cutting, or spot welding equipment in operation.